

Stubi Veneer Tie

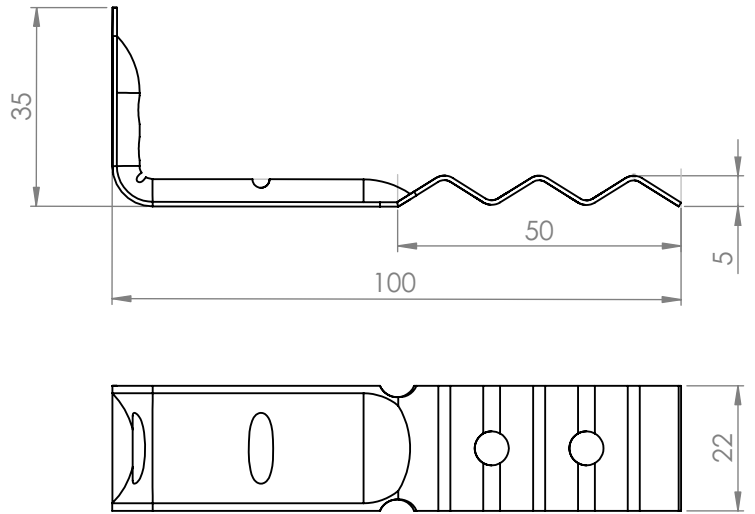

DESCRIPTION

Stubi face fix veneer tie

FEATURES

- Clay brick
- Maximum cavity 50mm
- Universal applications
- Australian design & tested AS/NZS 2699.2:2020

FIXING REQUIREMENTS

- S/Drilling treated pine screws 8g X 32mm galvanised class 3 finished / SS 316 (Timber)
- S/Drilling hex head 8g X 12mm galvanised class 3 finished / SS 316 (Metal)
- 30mm X 2.8mm dia connector nail galvanised/ SS 316 (Timber)

CORROSION CHARACTERISTICS

Hot dipped galvanising (R3)
 Stainless steel 316L (R4)
 Conforms to corrosion resistance set by AS/NZS 2699.2:2020 / AS 3700.

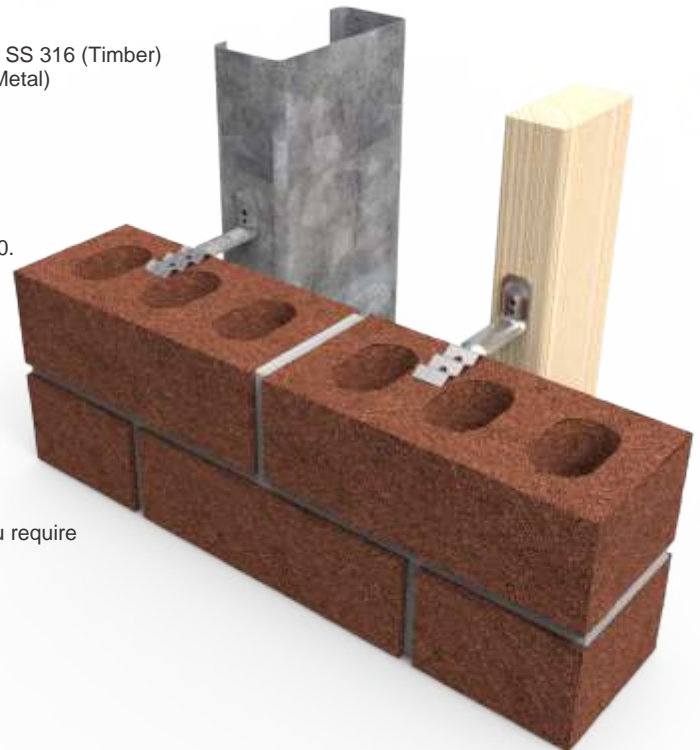

ORDERING INFORMATION

When ordering please supply use with the part number and quantity you require

STUBI-FACE-FIX-R4

PRODUCT CODE

MATERIAL

Specify
R3 for Hot dipped galvanised
R4 for Stainless steel 316L

Datasheet